

Serie **RAF**
raffinatore

VENTILATORI CENTRIFUGHI
VENTILATORI ASSIALI
VALVOLE STELLARI

CENTRIFUGAL FANS
AXIAL FANS
ROTARY VALVES

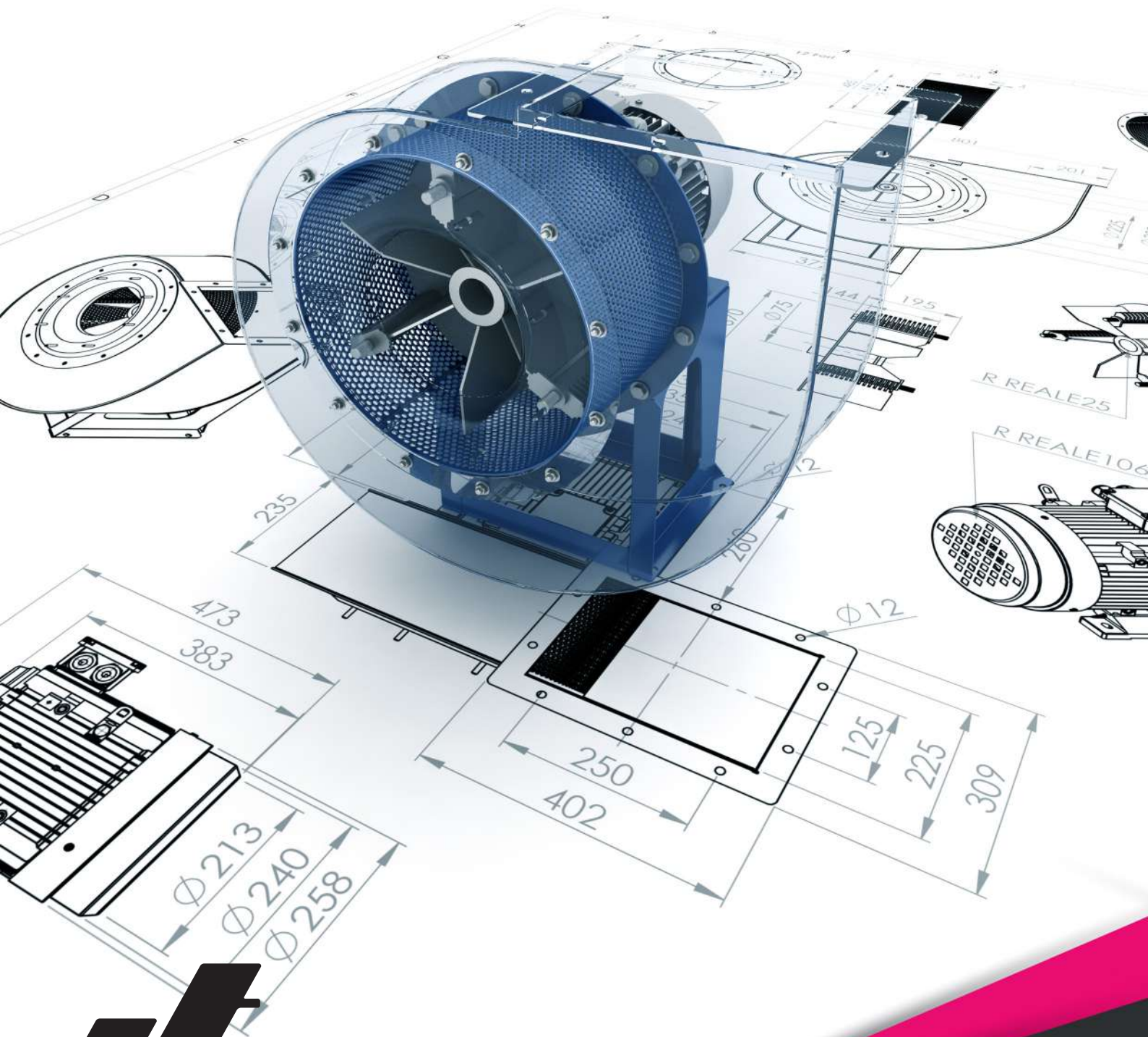

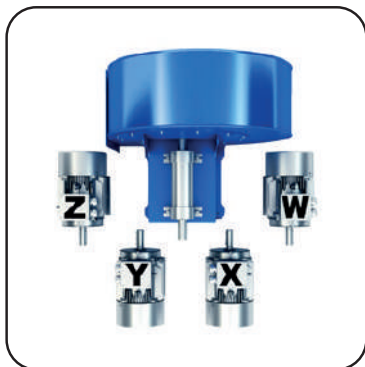

Posizioni convenzionali in pianta dei motori per trasmissione a cinghie.

Plan for motor positioning belt drive.

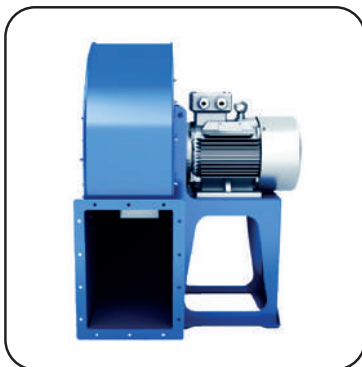

Esecuzione 4

Accoppiamento diretto, Girante a sbalzo calettata direttamente sull'albero del motore elettrico sostenuto dalla sedia. Massima temperatura di funzionamento in esecuzione standard: 60°C. In esecuzione speciale: 150°C.

Arrangement 4

Directly coupled fan blower splined to the shaft of the motor supported by the pedestal. Maximum working temperature standard 60°C. With special arrangements: 150°C.



Esecuzione 9

Simile all'esecuzione 1 per accoppiamento a cinghie, con il motore sostenuto sul fianco della sedia. Massima temperatura di funzionamento in esecuzione standard: 60°C. Con ventolina di raffreddamento: 300°C.

Arrangement 9

Similar of arrangement 1 for belt coupling, with motor supported on the pedestal side. Maximum working temperature standard 60°C. With small cooling disc 300°C.

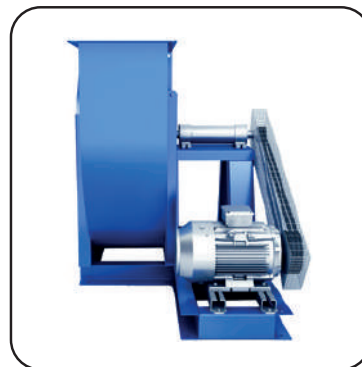

Esecuzione 12

Simile all'esecuzione 1 per accoppiamento a cinghie, con il motore e ventilatore montati sullo stesso basamento. Massima temperatura di funzionamento in esecuzione standard: 60°C. Con ventolina di raffreddamento: 300°C.

Arrangement 12

For belt coupling similar to arrangement 1, with motor and fan assembled on the same base. Maximum working temperature standard 60°C. With small cooling disc 300°C.

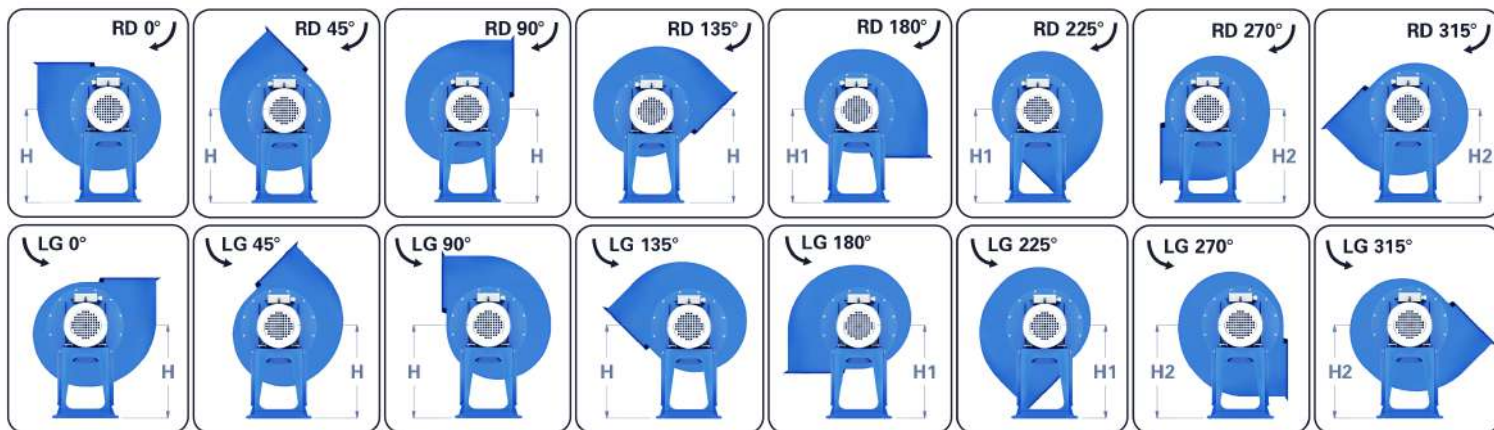

Per motivi costruttivi interni i ventilatori della grandezza 400+630 seguono un orientamento con angoli di 30° anziché 45°. Necessitando i 45° basterà farlo presente al momento dell'ordinazione.

For internal construction reasons, the fans with size 400+630 follow an orientation with angles of 30° instead of 45°. If you need the 45° just make it present at the time of ordering.

Tutti i dati di questo catalogo sono suscettibili di variazioni e miglioramenti.
La Ditta si riserva il diritto di apportare modifiche senza preavviso.

Values on this catalog are indicative and can be subject to modifications and improvements.
The Company reserves the right to make changes without prior notice.

I raffinatori **RAF** vengono impiegati nel caso in cui si necessiti l'aspirazione del prodotto da trattare. Riducono il volume di cippato di legno, plastica e altri materiali, nei processi di bricchettatura o pellettizzazione.

Esternamente identici ai ventilatori centrifughi, si differenziano all'interno perchè viene montata una girante con martelli oscillanti cementati atti ad assorbire gli urti, disegnati e spessorati specificatamente a seconda del prodotto da trattare. Inoltre viene montata una rete circolare attorno alla girante, facilmente smontabile e sostituibile che funge da vaglio, fino a quando il prodotto non ha raggiunto le dimensioni del foro della rete non viene rilasciato.

The refiners **RAF** are used in case the suction of the product to be treated is required. They reduce the volume of wood chips, plastics and other materials in briquetting or pelletizing processes.

Externally identical to centrifugal fans, they differ inside because an impeller is mounted with cemented oscillating hammers able to absorb the impacts, designed and thickened specifically according to the product to be treated. Furthermore, a circular net is mounted around the impeller, which can be easily removed and replaced, which acts as a screen, until the product has not reached the size of the hole in the net.



Le dimensioni del materiale in uscita e la sua produzione oraria, dipendono dai diametri dei fori della rete.

La produzione oraria diminuisce al diminuire del diametro dei fori della rete installata sul raffinatore.

The dimensions of the output material and its hourly output depend on the diameter of the holes in the net.

Hourly production decreases as the diameter of the holes in the net installed on the refiner decreases.

Tipo Type	rpm	kW	dB(A)	Caratteristiche Features		Produzione [kg/h] con rete raffinatori Refiner gridhole production [kg/h]			
				Pressione [mmH ₂ O]	Portata [m ³ /h]	G3	G6	G8	G10
RAF 350	2900	4	82	135	3500	35	85	105	175
RAF 400	2900	7,5	86	155	5500	55	135	155	300
RAF 450	2900	7,5	89	165	6500	65	160	180	350
RAF 451	2900	11	90	175	8000	80	180	200	400
RAF 500	2900	11	91	190	12000	100	230	250	500
RAF 501	2900	15	92	195	13000	115	260	280	550
RAF 560	2900	18,5	93	200	15000	130	300	320	600
RAF 561	2900	22	94	210	16000	145	330	350	650
RAF/TC 400	2900	7,5	88	96	3600	36	86	106	170
RAF/TC 450	2900	11	89	198	4100	41	98	118	189
RAF/TC 451	2900	15	90	200	5000	50	118	138	220
RAF/TC 500	2900	18,5	94	265	6900	69	160	180	288
RAF/TC 501	2900	22	95	255	8300	83	190	210	336
RAF/TC 560	2900	30	97	292	9700	97	225	245	392
RAF/TB 450	2900	5,5	85	288	1400	14	35	55	88
RAF/TB 500	2900	7,5	88	355	1800	18	45	65	104
RAF/TB 501	2900	11	89	345	2500	25	60	80	128
RAF/TB 560	2900	15	92	460	2300	23	55	75	120
RAF/TB 561	2900	18,5	93	450	3200	32	75	95	152
RAF/TB 630	2900	22	96	590	2900	29	70	90	144
RAF/TB 631	2900	30	97	575	4100	41	95	115	184
RAF/TB 711	2900	37	98	745	5200	52	120	140	224
RAF/TB 712	2900	45	99	740	6500	65	150	170	272

Esempio di portata e pressione con riferimento ad una rete con foro Ø 15 mm, materiale trattato: cippato di legno.
Example: features from grinder wood with Ø 15 mm hole grid.

Rete / Grid



Rete disponibili / Available grid
Fori rete / Holes grid:
Ø mm - 3, 4, 5, 6, 8, 10, 12, 15, 18, 20

Fori quadri per paglia e canapa.
Square holes for straw and hemp.

Girante RAF / RAF impeller

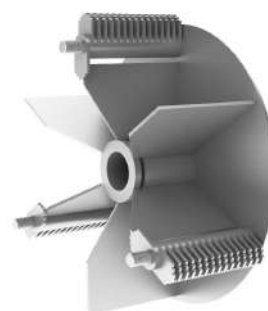

Tipo / Type		Peso Weight kgf	Raffinatore / Refiner										Basamento / Base													
Raffinatore Refiner	Motore Motor		A	B	C	D	E	F	G	H	H ₁	H ₂	I	J	K	L	M	N	O	P	Q	R	S	T	U	Ø
RAF 350	112 MA2	80	115	585	600	255	740	253	107	450	255	450	190	302	324	-	250	-	-	-	30	30	-	-	-	12
RAF 400	132 SB2	115	127	671	655	285	815	286	118	500	285	500	240	352	374	-	300	-	-	-	30	30	-	-	-	12
RAF 450 RAF 451	132 SB2 160 MA2	142 198	141	698 834	735	320	915	321	131	560	320	560	240 355	352 402	374 444	-	300 415	-	-	-	30	30	-	-	-	12
RAF 500 RAF 501	160 MA2 160 MB2	222	157	866	832	360	1000	355	148	600	360	600	355	402	444	-	415	-	-	-	30	30	-	-	-	12
RAF 560 RAF 561	160 LA2 180 MA2	279 323	177	880 935	940	400	1126	390	165	670	400	670	355 400	402 448	444 490	692	415 460	327	53	632	-	23	375	23	790 835	12
RAF/TC 400	132 SB2	121	105	622	655	285	815	319	95	500	285	500	240	352	374	-	300	-	-	-	30	30	-	-	-	13
RAF/TC 450 RAF/TC 451	160 MA2 160 MB2	213 223	115	783	735	320	915	357	106	560	320	560	355	402	444	-	415	-	-	-	30	30	-	-	-	13
RAF/TC 500 RAF/TC 501	160 LA2 180 MA2	238 260	127	807	832	360	1000	396	118	600	360	600	355 400	402 448	444 490	-	415 460	-	-	-	30	30	-	-	-	13
RAF/TC 560	200 LA2	362	142	922	940	400	1126	436	132	670	400	670	440	506	568	692	500	260	53	632	-	30	366	23	813	13
RAF/TB 450	132 SA2	88	78	560	645	300	715	265	70	400	300	400	240	352	374	-	300	-	-	-	30	30	-	-	-	12
RAF/TB 500 RAF/TB 501	132 SB2 160 MA2	114 154	86	585 690	715	335	795	298	78	450	335	450	240 355	352 402	374 444	-	300 415	-	-	-	30	30	-	-	-	12 14
RAF/TB 560 RAF/TB 561	160 MB2 160 LA2	185 199	95	740	805	375	890	338	89	500	375	500	355	402	444	-	415	-	-	-	30	30	-	-	-	14
RAF/TB 630 RAF/TB 631	180 MA2 200 LA2	279 346	105	760 851	910	425	1000	381	99	560	425	560	400 440	448 506	490 568	-	460 500	-	-	-	30	30	-	-	-	17 19
RAF/TB 711 RAF/TB 712	200 LB2 225 M2	411 492	115	860 900	1015	475	1122	426	108	630	475	630	440 440	506 556	568 616	-	500 540	-	-	-	30	30	-	-	-	19

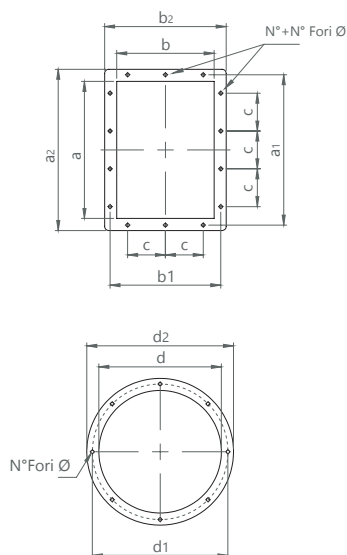

Raffinatore Refiner	Flangia Aspirante Inlet Flange					Flangia Premente Outlet Flange								
	d	d ₁	d ₂	N°	Ø	a	b	a ₁	b ₁	a ₂	b ₂	c	N°	Ø
RAF 350	255	292	325	8	12	288	205	332	249	368	285	125	6+4	12
RAF 400	287	332	365	8	12	322	229	366	273	402	309	125	6+4	12
RAF 450	320	366	400	8	12	361	256	405	300	441	336	125	6+4	12
RAF 500	360	405	440	8	12	404	288	448	332	484	368	125	8+6	12
RAF 560	405	448	485	12	12	453	322	497	366	533	402	125	8+6	12
RAF/TC 400	255	292	325	8	12	288	205	332	249	368	285	125	6+4	12
RAF/TC 450	287	332	365	8	12	322	229	366	273	402	309	125	6+4	12
RAF/TC 500	320	366	400	8	12	361	256	405	300	441	336	125	6+4	12
RAF/TC 560	360	405	440	8	12	404	288	448	332	484	368	125	8+6	12
RAF/TB 450	205	241	274	8	12	185	131	219	165	255	201	112	4+2	12
RAF/TB 500	228	265	298	8	12	207	148	241	182	275	216	112	4+4	12
RAF/TB 560	255	292	324	8	12	231	166	265	200	299	234	112	4+4	12
RAF/TB 630	287	332	365	8	12	258	185	292	219	326	253	112	6+4	12
RAF/TB 710	320	366	400	8	12	288	205	332	249	368	285	125	6+4	12

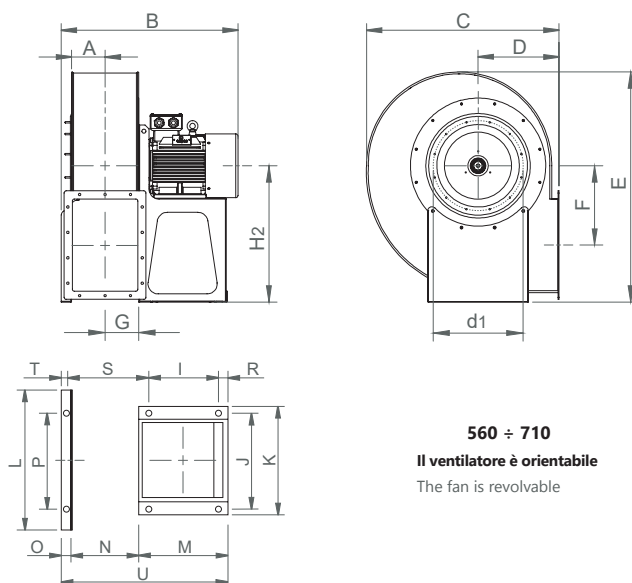
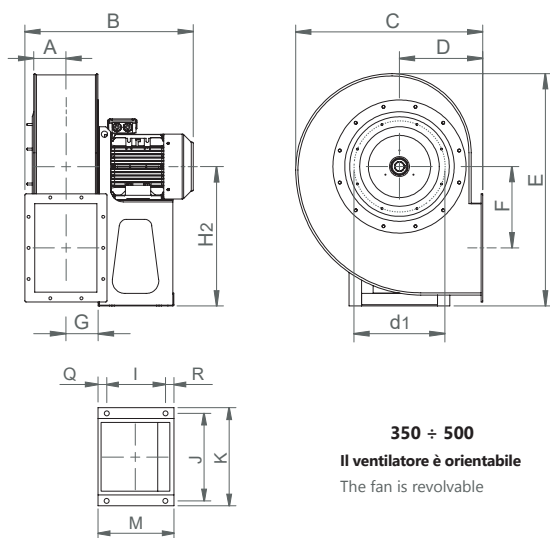

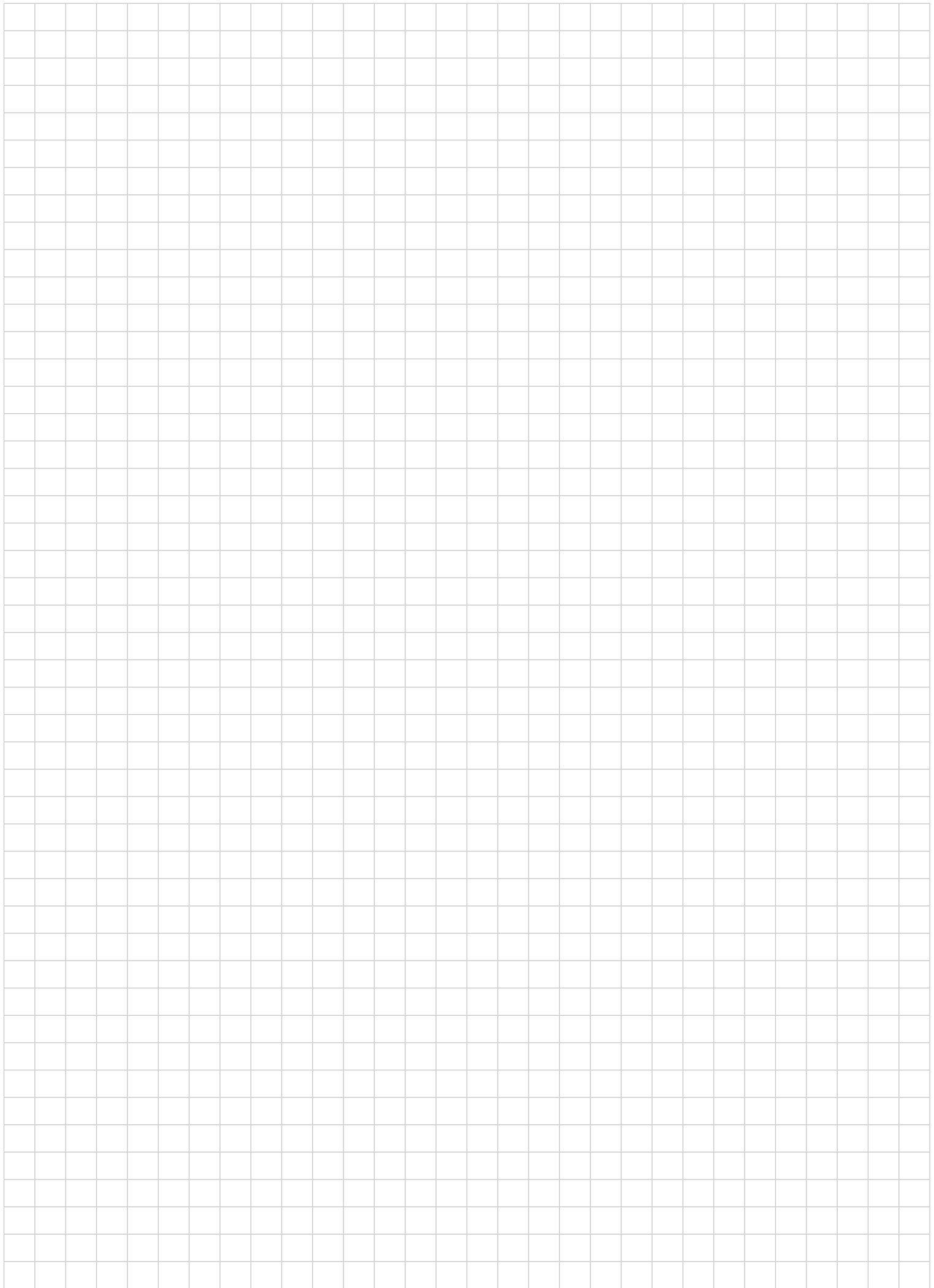



Via Brunelleschi 5/E - 50013
Capalle, Campi Bisenzio
Firenze, Italia
Tel. +39 055/8951259
Fax. +39 055/8952636

info@italsime.com - www.italstime.com

